

ROSS Inline High Shear Mixers with Solids/Liquid Injection Manifold 400 Series SLIM Specifications and Dimensions

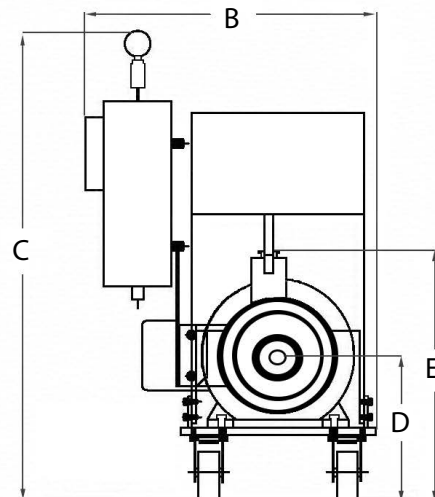
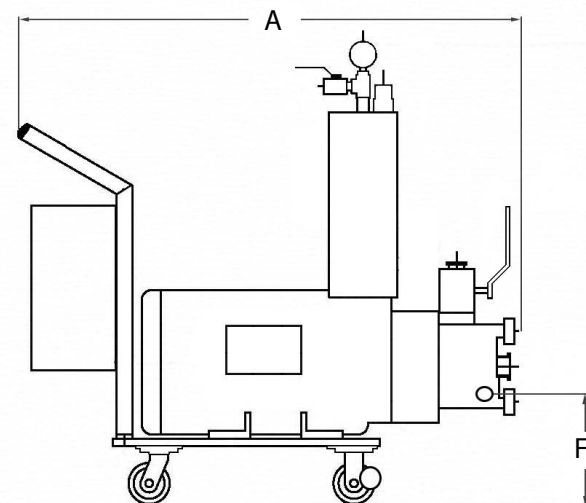

STANDARD FEATURES:

- Driven by an explosion-proof motor designed for 230/460 volt, 3 phase, 50/60 Hz.
- Large square stator and special four-blade SLIM rotor.
- Double mechanical seal with Viton elastomers and barrier system.
- Stainless steel type 316 wetted parts polished to #4/32 Ra finish.
- Stainless steel type 304 cart with caster wheels for easy movement of mixer except for 450SC which is on leveling pads and forklift tubes for movement.
- All non-stainless steel external surfaces coated with a two-part acrylic urethane enamel paint.
- 2 ft³ stainless steel 316 hopper for powder loading.

AVAILABLE OPTIONS:

- Hose and wand attachment in addition to or in place of a hopper.
- Special elastomers including Kalrez.
- ANSI flange inlet and outlet connections, in lieu of tri-clamp.
- Hardened materials of construction such as a stainless steel type 440C stator, Stellite tipped rotor, or Kolsterised rotor and stator.
- Special motors including stainless steel, wash-down, and various voltages and frequencies.
- Controls include variable frequency drives, explosion-proof operator stations, and touch screen controls.

| Model | HP | Rotor | | Connection Size | | | Overall Dimensions | | | Distance From Ground | | | Weight | Maximum Flow Rate (Water) |
|----------|----|-------|----------|-----------------|---------|----------|--------------------|-----------|------------|----------------------|----------|------------|-----------|---------------------------|
| | | RPM | Diameter | Inlet | SLIM | Outlet | Length (A) | Width (B) | Height (C) | Inlet (D) | SLIM (E) | Outlet (F) | | |
| 401SC-15 | 15 | 3,600 | 2.5" | 1.5" | 1.5" | 1.5" | 44.2" | 25.5" | 36.9" | 11.9" | 22.1" | 9.7" | 750 lbs | 90 gpm |
| | | | 63.5 mm | 38.1 mm | 25.4 mm | 38.1 mm | 1,123 mm | 648 mm | 937 mm | 302 mm | 561 mm | 246 mm | 340 kg | 340 lpm |
| 405SC-25 | 25 | 3,600 | 3.5" | 2" | 1.5" | 2" | 50.2" | 27" | 45" | 13.4" | 23.5" | 11.4" | 900 lbs | 330 gpm |
| | | | 88.9 mm | 50.8 mm | 38.1 mm | 50.8 mm | 1,275 mm | 686 mm | 1,143 mm | 340 mm | 597 mm | 290 mm | 408 kg | 1,250 lpm |
| 430SC | 30 | 1,800 | 7" | 3" | 2.5" | 3" | 53.5" | 30.7" | 45" | 13.5" | 29.3" | 8.2" | 1,200 lbs | 800 gpm |
| | | | 177.8 mm | 76.2 mm | 63.5 mm | 76.2 mm | 1,359 mm | 780 mm | 1,143 mm | 343 mm | 744 mm | 208 mm | 544 kg | 1,890 lpm |
| 450SC | 50 | 1,200 | 10.5" | 4" | 3" | 4" | 58" | 31" | 35" | 13.5" | 34.1" | 6" | 2,100 lbs | 1,600 gpm |
| | | | 267 mm | 101.6 mm | 76.2 mm | 101.6 mm | 1,473 mm | 787 mm | 889 mm | 343 mm | 866 mm | 155 mm | 953 kg | 6,057 lpm |



Charles Ross & Son Company

710 Old Willets Path
Hauppauge, NY 11788
USA

631-234-0500 / 800-243-ROSS(7677)
sales@mixers.com
mixers.com